

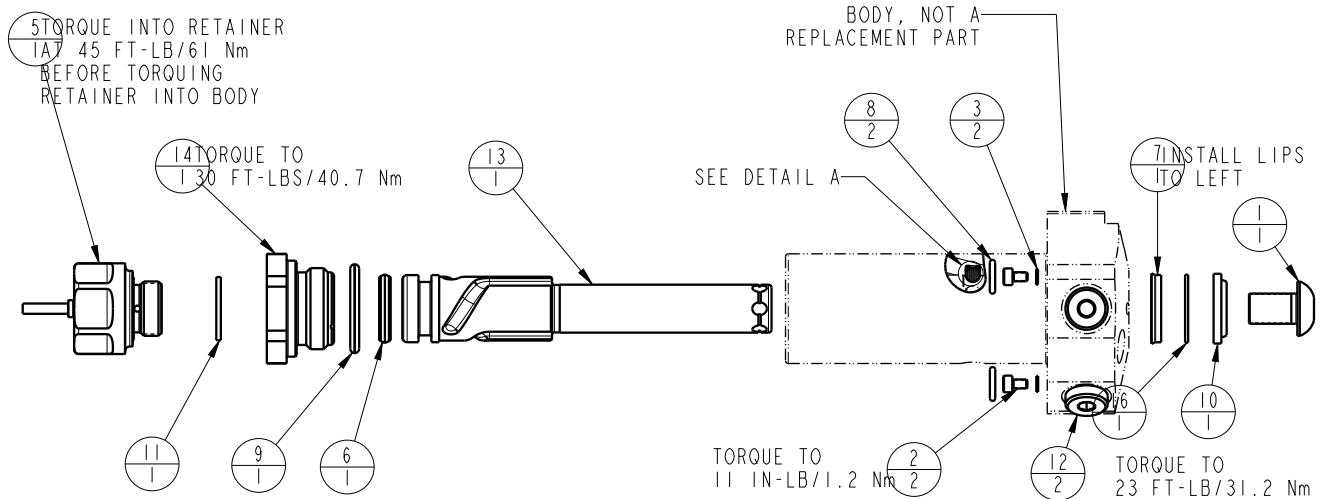

NO	QTY	PART NO	DESCRIPTION	STD SEAL KIT	FKM SEAL KIT
1	1	21500009	SCREW, CAP, BTNH, M10 X 16, ALY		
2	2	21500018	SCREW, CAP, SOCH, M3 X 5, ALY		
3	2	21500200	WASHER		
4	3	23600011	BALL, STEEL, ALLOY, .187	X	X
5	1	29740200	SENSOR, ULTRASONIC, M12, 1m		
6	1	39010018	SEAL,CROWN,11/16x7/8x5/32	X	39V10018
7	1	39010020	SEAL,BEVEL W/HEEL INSERT,5/8 x 1/8 x 7/8	X	39V10020
8	2	39050042	O-RING, (-011)	X	39051025
9	1	39051031	O-RING, (-912)	X	X
10	1	39053001	WIPER,SNAP-IN, (5/8)	X	X
11	1	43000040	O-RING, DIN3869, M18		
12	2	43068004	PLUG, SOCH, G1/8		
13	1	47510920	PLUNGER, SC, HS, 1100/4.9KN, LH, LS, US		
14	1	81400081	RETAINER, SC, HS, 1100, US		
15	3	90199957	ASSY,BALLSEAT,SC,1100	X	X
16	1	39F54001	BU RING,(-208 CUSTOM)	X	X
N/A	N/A	60414502	KIT, SEAL, STANDARD	NOTED	N/A
N/A	N/A	6V414502	KIT, SEAL, FKM	N/A	NOTED



PARTS LIST	 VEKTEK VEKTEK, INC. 1334 E. SIXTH AVE. P.O. BOX 625 EMPORIA, KS. 66801 U.S.A.
	ASSEMBLIES AFFECTED 41460524US
PARTS LIST, ASSY, SC, TF, TC, A.9KN, DA, LH, LS, US	
SIZE A	MPL1448
DATE: 3/24/25	REV A

A	5660	RELEASE	ALS	3/24/25
REV	IN ACCORDANCE WITH ECN	EFFECTIVE DATE	REVISED BY	DATE
DRW BY: ALS	DRAWING STATUS: Released			
DATE: 3/23/25	PRODUCTION APPROVED FOR RELEASED STATUS ONLY			